

**Humidistats**  
**HST**

- Measuring ranges from 0 to 100 %RH and 0 to +50°C, -20 to +80°C
- RCR relay 3A/230Vac. Power supply 24Vac/Vdc
- Visual alarm, red LED in front
- IP 65 and IP 30 ABS housing, with display
- Alternating display of humidity and temperature
- Quick and easy mounting with the "1/4 turn" system with wall-mount plate

**Features of the transmitter**

**Humidity**

Working principle : the measurement of temperature and humidity is made by only one digital component CMOS (complementary metal-oxide semiconductor) including a capacitive element and a thermistor. This technology guarantees an excellent stability in the long term, along with a great accuracy of the measurement.

Measuring range ..... 0 to 100 %RH  
 Unit of measurement ..... % RH  
 Accuracy \* ..... ±2% of reading ±2%RH  
 in the range of 10 to 90%RH

Response time ..... 1/e (63%) 4 s  
 Resolution ..... 0,1%RH  
 Type of fluid ..... air and neutral gases

**Temperature**

Measuring range ..... 0 to +50°C (standard model)  
 -20 to +80°C (duct mount and remote sensor)  
 Unit of measurement ..... °C, °F  
 Accuracy \* ..... ±1% of reading ±0,4°C in the range +5 to +80°C  
 ±2% of reading ±0,6°C in the range -20 to +5°C

Response time ..... 1/e (63%) 15 s  
 Resolution ..... 0,1°C  
 Type of fluid ..... air and neutral gases

**Features of the housing**

Housing ..... ABS  
 Fire-proof class ..... HB as per UL94  
 Dimensions ..... see drawing beside  
 Protection ..... IP 30 (standard model)  
 IP 65 (duct mount and remote sensor)  
 Display ..... 5-digit LCD. Dimensions 50 x 15 mm  
 Alternating display of humidity and temperature.  
 Height of the digits ..... 10 mm  
 Cable grip ..... for cables Ø 7 mm max.  
 Weight ..... 145 g

**Technical specifications**

Output ..... 1 RCR relay 3A/230 Vac  
 Relay and alarm status ..... red LED in front  
 Set point ..... 2 configurable set points (°C and %RH)  
 Power supply ..... 24 Vac/Vdc ±10%  
 Consumption ..... 2 VA  
 Electro-magnetical compatibility ..... EN 61326  
 Electrical connection ..... Screw terminal block for cables Ø1.5mm<sup>2</sup> max.  
 Connection to PC ..... Kimo RS 232 cable  
 Working temperature (housing) ..... 0 to +50°C  
 Working temperature (probe) ..... 0 to +50°C (standard model)  
 -20 to +80°C (duct mount and remote sensor)  
 Storage temperature ..... -10 to +70°C  
 Environment ..... air and neutral gases

\*All the accuracies indicated in this technical datasheet were stated in laboratory conditions, and can be guaranteed for measurements carried out in the same conditions, or carried out with calibration compensation.

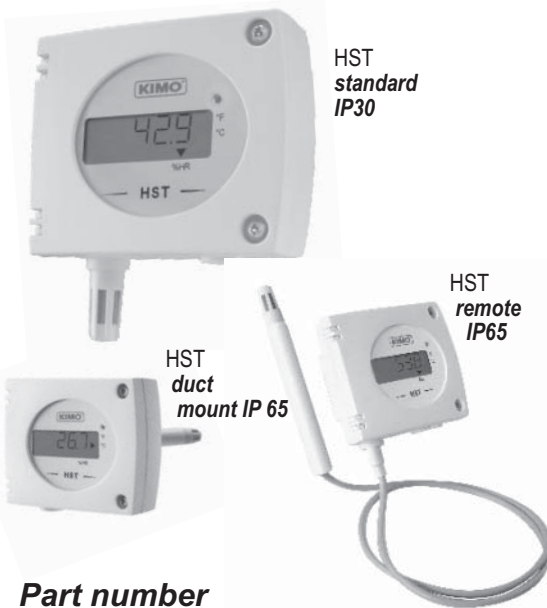

**Part number**

To order, just add the code to complete the part number :

Probe	
M	Standard
A	Duct mount
D	Remote

HST -

Example : HST-A  
 Model : humidistats HST with a duct mount probe.

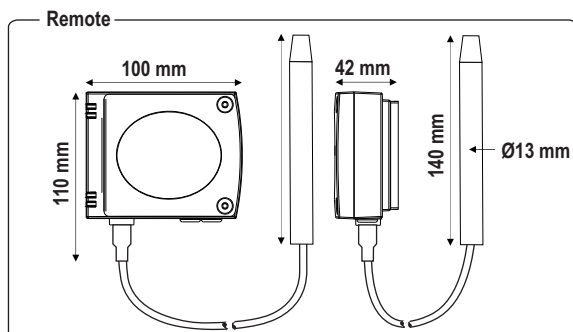
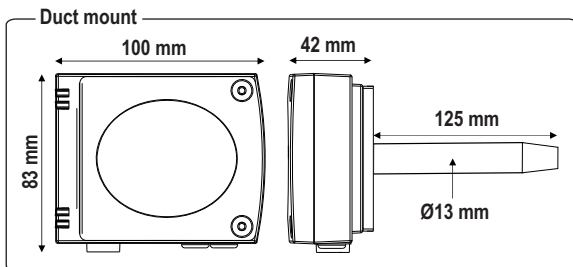
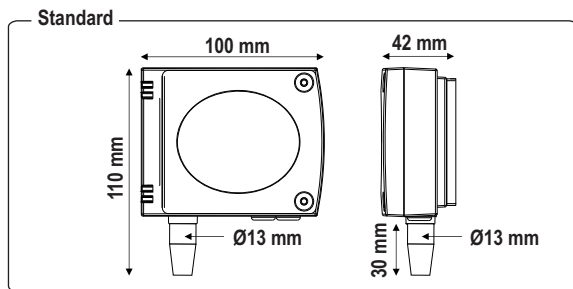

## Connection

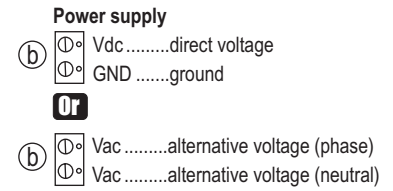
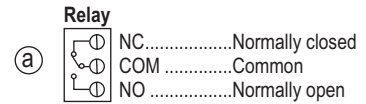
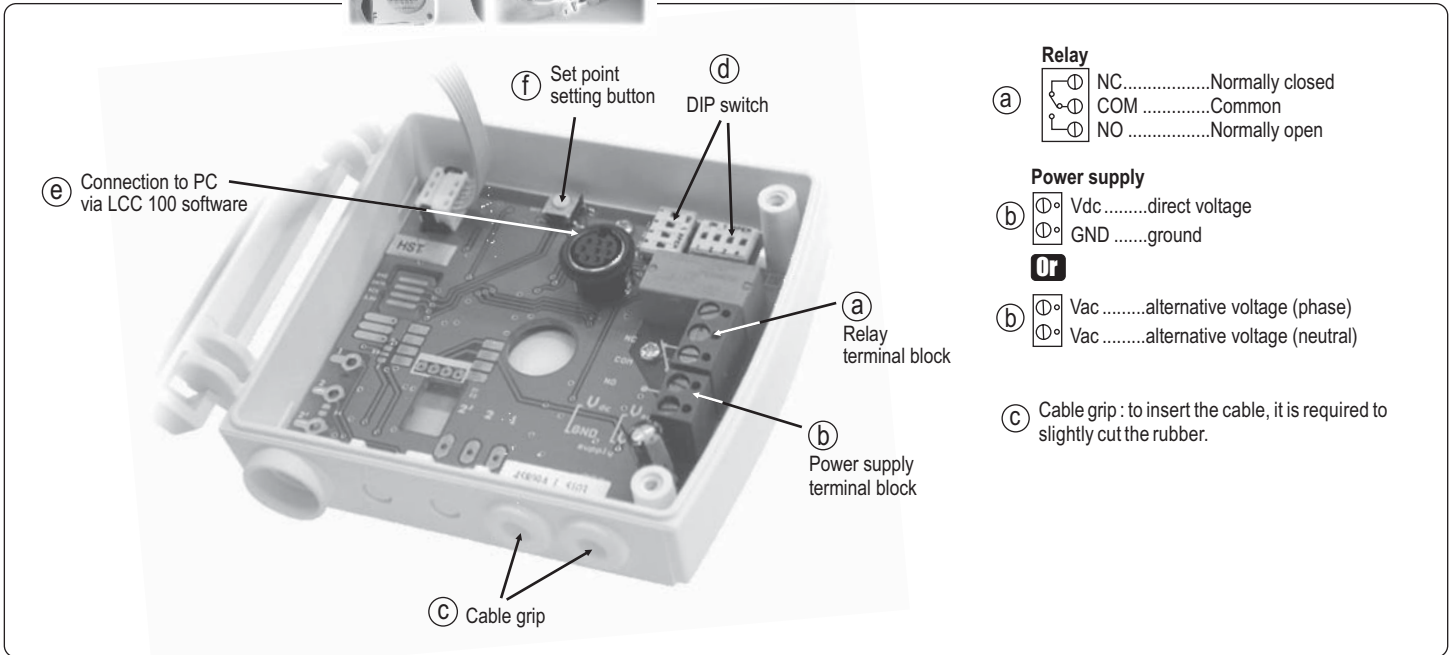

(c) Cable grip : to insert the cable, it is required to slightly cut the rubber.

## Electrical connections - as per norm NFC15-100

This connection must be made by a qualified technician. To make the connection, the transmitter must not be energized.

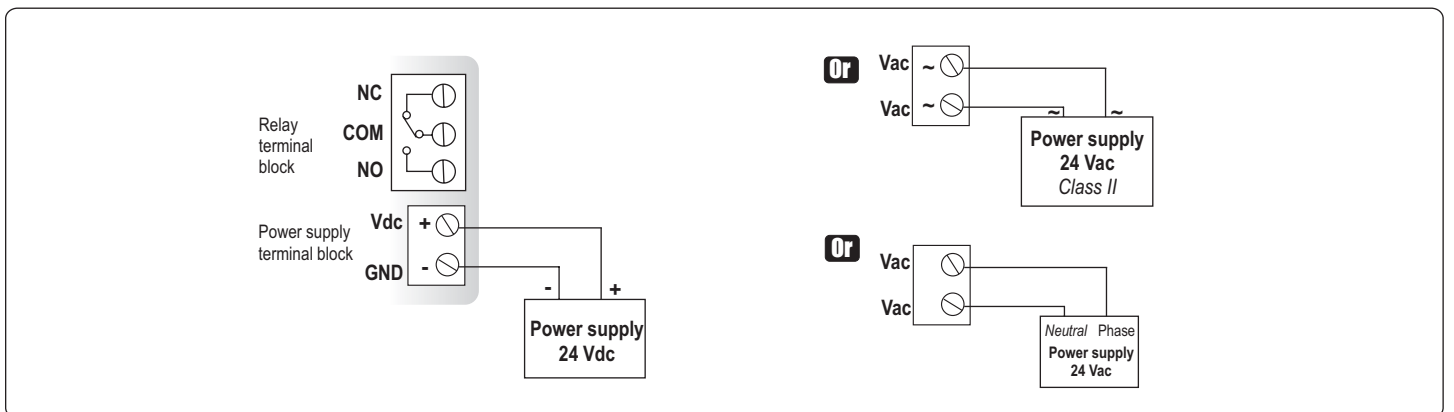

## Configuration

Configuration of measuring units, set points can be carried out different ways : **DIP switch, push-button and/or software** (connections (e), (f) and (d) on the drawing "connection").

### Configuration of measuring units by DIP switch

To configure the transmitter, please unscrew the 2 screws from the housing, and then open it.

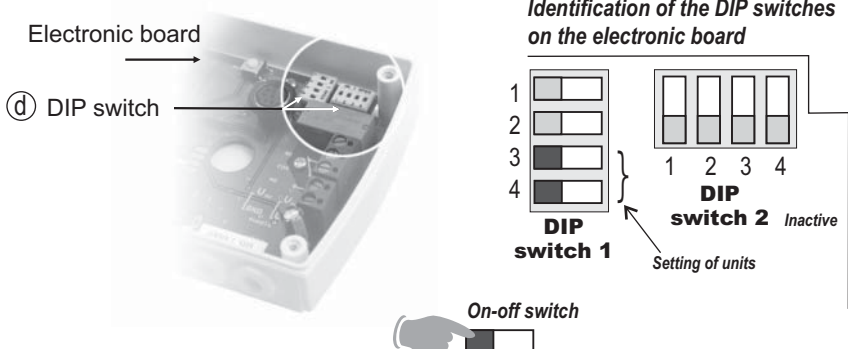

To configure the transmitter, **it must not be energized**. Then, you can make the settings required, thanks to the DIP switches (as shown on the drawing beside). When the transmitter is configured, you can power it up.

**Caution !**

Please follow carefully the combinations beside with the DIP switch.

If the combination is wrongly done, the following message will appear on the display of the transmitter "CONF ERROR". In that case, you will have to unplug the transmitter, replace the DIP switches correctly, and then power the transmitter up.

## • Setting of units

To set the measuring unit, please put the on-off switches 3 and 4 as shown beside.

Configurations	°C	°F
1	<input type="checkbox"/>	<input type="checkbox"/>
2	<input type="checkbox"/>	<input type="checkbox"/>
3	<input type="checkbox"/>	<input checked="" type="checkbox"/>
4	<input checked="" type="checkbox"/>	<input type="checkbox"/>

## ▪ Set points configuration with the push-button

Power the transmitter up : it will then display its current configuration.  
To modify the configuration, please proceed as follows :  
Remove the 2 screws from the housing and open it.  
The settings are done with the button located on the electronic board (see photo beside).

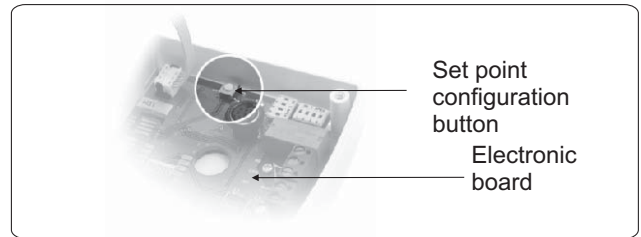

### Principle :

- By pressing on this button for more than 3 seconds, you can validate the setting and go to the next setting.
- By pressing quickly on this button, you can increment a value and scroll down the different options or values.

### This button enables :

1- to activate/deactivate an alarm (set point)

AL.ON ▶ AL.OFF ▶

2- to program the action of the alarm (rising/falling/regulation action)

3- to set the set point value

0000.0 ▶

4- to set the time-delay (temporisation)

00.SEC ▶

To set the different options :

### 1- Activating/deactivating the alarm :

After pressing the set point configuration button for more than 3 seconds, **AL.OFF** will be displayed, **AL.ON** (depending on the last configuration of the transmitter).

Afterwards, by briefly pressing on this button, you can switch between **AL.ON** (alarm on) and **AL.OFF** (alarm off).

To validate your choice, press again for 3 seconds. If you chose **AL.OFF**, then you will exit the configuration mode and switch back to the measurement mode. If you chose **AL.ON**, you will move to the next parameter.

### 2- Programming the action of the alarm (rising/falling/regulation action) :

**Rising action (1 set point)** : the alarm will activate when the measure **exceeds** the set point and will stop when the measure goes **below** the set point.

**Falling action (1 set point)** : the alarm will activate when the measure goes **below** the set point and will stop when the measure goes **above** the set point.

**Regulation mode (2 set points)** : the set point values will determine the action type. Two possibilities are available:

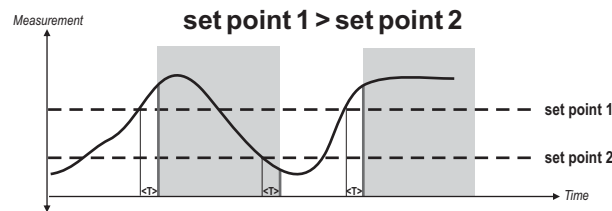

Measure > set point 1 → Alarm activation  
Measure < set point 2 → Alarm stop  
set point 2 ≤ Measure ≤ set point 1 → No change

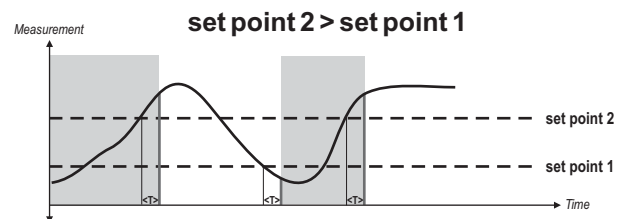

Measure < set point 1 → Alarm activation  
Measure > set point 2 → Alarm stop  
set point 1 ≤ Measure ≤ set point 2 → No change

Press the button for 3 seconds to confirm your choice. You will then move on to the last parameter.

### 3- Programming the set point value :

The set point is a limit which, when being reached and/or exceeded, activates the relay and the visual red LED alarm.

The first digit will start to blink, by briefly pressing on the button, you can choose if the set point will be either positive (0) or negative (-). Then press the button during 3 seconds to confirm your choice. The second digit will start to blink. Press the button briefly to change the value. Then press the button during 3 seconds to confirm your choice. Repeat this sequence until you have reached the last digit and then confirm the set point. If you selected regulation mode , you will program the second set point.

### 4- Setting of the time-delay (dead band temporisation 60 sec max) :

When the set point is reached and/or exceeded, the time-delay will wait the specified time before energizing the relay, if the set point is still reached and/or exceeded.

When the first digit starts blinking, press briefly on the button to change the value. Then press the button during 3 seconds to confirm your choice. Repeat the process until all digits have the desired value and press the button for 3 seconds to confirm your choice.

The programming is now done and the display switches back to the measurement mode.

## ■ Initialization of the transmitter

When the transmitter is powered up, it initializes and displays the digits  $\boxed{0.0000}$ , and then its configuration including :

- 1 - the measuring range
- 2 - the status of the alarm
- 3 - action of the alarm (rising, falling or regulation action)
- 4 - the set point
- 5 - time-delay (dead band temporisation)

### 1- The measuring range

The following message is displayed :  $\boxed{Lo}$ . This is the low value of the measuring range, and its digit value : **ex** :  $\boxed{-500}$ .

The following message is displayed :  $\boxed{Hi}$ . This is the high value of the measuring range and its digit value : **ex** :  $\boxed{1000}$ .

The arrow displayed (at the bottom or on the right of the screen) is relative to the unit of measurement : **ex** : from -500 to 1000 Pa.

### 2 - The status of the alarm

When the alarm is off, the following message is displayed :  $\boxed{ALOFF}$ .

When the alarm is on, the following message is displayed :  $\boxed{ALON}$ .

• When the alarm is off, the transmitter displays  $\boxed{----}$ , which confirms the end of initialization and that you can start the measurements .

• When the alarm is on, the transmitter displays the parameters relative to the relay (set point, program of the alarm, time-delay).

### 3 - Action of the alarm (rising or falling action)

If the relay is programmed in rising action, the following message is displayed :  $\boxed{- - r - -}$ .

If the relay is programmed in falling action, the following message is displayed :  $\boxed{- - l - -}$ .

This message is displayed : **ex** :  $\boxed{250}$ , which means that the alarm

If the relay is programmed in regulation mode, the following message is displayed  $\boxed{0}$ .

### 4- The set point (alarm on)

This message is displayed : **ex** :  $\boxed{250}$ , which means that the alarm will be activated as soon as the measurement exceeds this value.

If you chose regulation mode  $\boxed{0}$ , the second set point will appear.

### 5- The time-delay (alarm on)

This message is displayed :  $\boxed{15E4}$ .

The temporisation is in seconds (from 0 to 60 sec.).

After having displayed the configuration, the transmitter displays  $\boxed{----}$  which confirms that the initialization is finished and you can start the measurements.

## ■ Configuration via software

(with the optional LCC100 software)

### An easy and friendly way to configure !

You can configure the measuring units, the set point the time-delay....

For all the parameters (humidity and temperature)

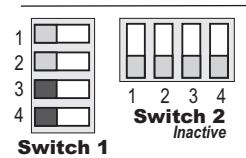

- In order to balance an eventual drift of the transmitter, you can add an offset to the value displayed by the HST :  
=> example : the HST indicates 48%RH, the standard reference indicates 45%RH  
=> via the LCC100, you can add an offset of "-3" to the value.

To access the configuration via software, you must first position **the DIP switches**, as per the following picture (shown beside), and then connect the cable to the transmitter (see "connection" drawing).

**Please refer to the user manual of the LCC 100 to make the configuration.**



### ⚠ Caution !

The configuration can be made either via switch, or via software (you can not combine both solutions).

## ■ Mounting

Installation : mount the ABS plate on the wall (this plate is supplied with the transmitter). Drilling :  $\varnothing$  6 mm, with the screws and pins supplied with the transmitter. Insert the transmitter into the plate (see points A of the drawing shown beside), by tilting it at 30°. Rotate the housing in clockwise direction until you hear a "click" which confirms that the transmitter is correctly installed.

For the model with remote sensor, an additional drilling of  $\varnothing$ 14 mm must be done before mounting the plate.

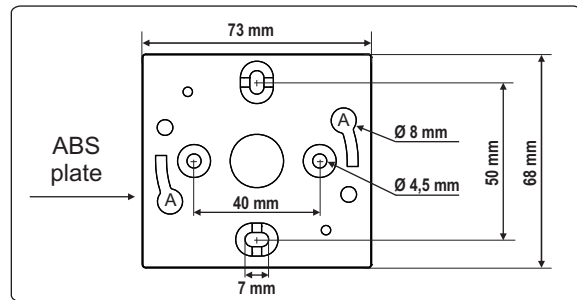

## ■ Maintenance

Please avoid any aggressive solvent.

Please protect the transmitter and its probes from any cleaning product containing formol, that may be used for cleaning rooms or ducts.

### Options

- Power supply class 2, input 230 Vac, output 24 Vac, ref.KIAL-100A
- Configuration software LCC 100 supplied with connection RS 232 cable



### Optional accessories

- Stainless steel sliding connection
- PC connection gland
- ABS clamp with connection gland
- Stainless steel clamp
- Wall-mounting plate for remote humidity probe

[www.kimo.fr](http://www.kimo.fr)

### EXPORT DEPARTMENT

Tel : + 33. 1. 60. 06. 69. 25 - Fax : + 33. 1. 60. 06. 69. 29  
e-mail : [export@kimo.fr](mailto:export@kimo.fr)



Distributed by : **PRC Technologies Corp., Ltd.**

Tel : 02 530 1714, 02 530 1619, 02 530 1621

Fax : 02 530 1731

[info@prctechth.com](mailto:info@prctechth.com) [www.prctechth.com](http://www.prctechth.com)