

PM-VS
Sensors for humidity and temperature
with RS232 signal level converter
 for digital transfer of the measurement values
 Rod and industrial designs
 up to 200°C and up to 25 bar
 with **exchangeable „Plug and Measure Units“ PMU**

Description

The PM-VS transmitters by Galltec+Mela combine digital plug-and-measure technology with the advantages of industrial sensors which can be used up to a temperature of 200°C, or respectively, up to a pressure of 25 bar and are thus particularly suitable for use in demanding industrial applications.

The capacitively measured humidity and temperature values are calculated in the calibrated Plug-and-Measure Unit PMU, with the calibration values stored there, and are passed on as digital measurement values. The PMU measuring heads can be factory-calibrated and readjusted using software.

This line of sensors has got a digital RS232 output and is suitable for data transfer via the network and the Internet. This line of sensors is designed for a permanent connection.

General Technical Data

measuring medium air, non-aggressive
 supply voltage, external 5...30 VDC
 or RS232 level (RTS, DTR)
 consumption of electronics < 7 mA
 electromagnetic compatibility EN 61326-1 / A1
 max. guaranteed transfer distance for RS232 15 m
 max. ambient temperature at the housing (PMO).....85° C
 degree of protection housing (PMO) IP64
 measuring head (PMU) IP30

Technical Data for Humidity and Temperature

Humidity
 measuring range 0...100% rh
 measuring accuracy 10...90% rh at 23° C ±1.5% rh
 <10%rh and >90%rh ±2% rh
 influence of temperature (TK) <0.05% rh/K
 response time at v>1.5m/s < 10 s

Temperature
 measuring element (ref. DIN IEC 751) Pt1000 1/3-DIN cl.B
 accuracy @ 23°C ±0.15 K
 influence of temperature (TK) <0.005 K/K

Type Survey

Type	Product No.	Measuring Range		PMU-Type	max. ambient temperature at PMU	Output
		rel. humidity	temperature			
PM15VS	620101023583	0 ... 100 % rh	-40 ... +85°C	PMU-V	-40 ... +85°C	RS232
PM80VGS		0 ... 100 % rh	-40 ... +85°C	PMU-V	-40 ... +85°C	RS232
PM80VKS		0 ... 100 % rh	-50 ... +150°C	PMU-VKS	-50 ... +150°C	RS232
PM80VZS.H		0 ... 100 % rh	-60 ... +200°C	PMU-VZS.H	-60 ... +200°C	RS232
PM80VZS.HD		0 ... 100 % rh	-60 ... +200°C	PMU-VZS.HD pressure-proof up to 25 bar	-60 ... +160°C	RS232

Special types on demand
 Further technical data and specifications see page 2

Mechanical specifications

PM15VS - rod sensor

ambient conditions	-40 ... +85°C / 0...100% rh *)	
housing	PMO15VS	stainless steel, Ø 15 mm
cable	PMO15VS	AWG26C-UL, 5 m
measuring head	PMU-VS	stainless steel, Ø 15 mm
filter	PMU-VS	integrated PTFE filter with ZE04

PM80VGS - wall sensor

ambient conditions	-40 ... +85°C / 0...100% rh *)	
housing	PMO80VGS	alu die-casting, wall mounted
measuring head	PMU-VS	stainless steel, Ø 15 mm
filter	PMU-VS	integrated PTFE filter with ZE04

PM80VKS - duct sensor

ambient conditions	-50 ... +150°C / 0...100% rh *)	
housing	PMO80VKS	alu die-casting, duct mounted
measuring head	PMU-VKS	stainless steel, Ø 15 mm
filter	PMU-VKS	integrated PTFE filter with ZE04

PM80VZS.H

ambient conditions	-60 ... +200°C / 0...100% rh *)	
housing	PMO80VGS	alu die-casting, wall mounted
measuring head	PMU-VZS.H	stainless steel, teflon cable (1.5m)
filter	PMU-VZS.H	integrated PTFE filter with ZE04

PM80VZS.HD

ambient conditions	-60 ... +160°C / 0...100% rh *)	
housing	PMO80VGS	alu die-casting, wall mounted
measuring head	PMU-VZS.HD	stainless steel, teflon cable (1.5m)
filter	PMU-VZS.HD	integrated PTFE filter with ZE04
pressure resistance of PMU	up to 25 bar, screw-in head 3/8``	

*) see page 3

Operating software HyperTerminal (Windows)

The sensors in the series PM-VS can be read via the Hyper Terminal programme from Windows. The picture below shows the character string of the data issued by the PMU.

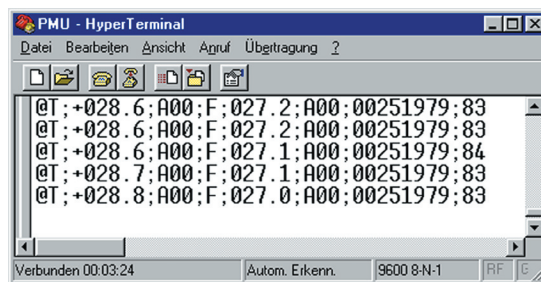

Connection settings

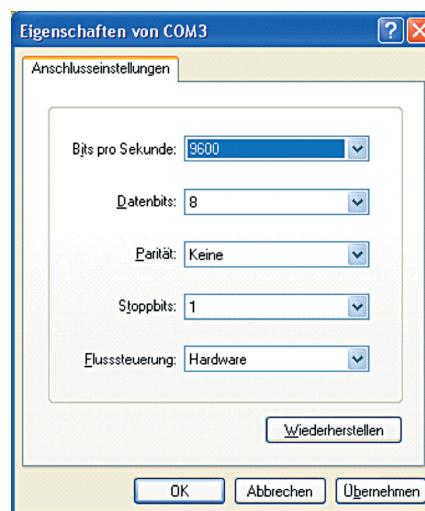

Notes on ASCII protocol

start of protocol	end of protocol	separation sign
@	"CR" and "LF"	“, “

The measurement data is sent in the measurement phase as ASCII-protocol on the TxD-pin:

@T	<sign>	<temperature>	<alarm-code>	F	<humidity>	<alarm-code>	<serial-number>	<check-sum>	<CR>	<LF>
----	--------	---------------	--------------	---	------------	--------------	-----------------	-------------	------	------

Example:

@T; + 021.37; A00; F; 038.92; A00; 00000121; 38 control character Carriage Return control character Line Feed

The check sum is calculated as follows:

$$\text{check sum} = 255 - (\sum_{\text{dez}} \% 256) = \text{check sum}_{\text{dez}} = \text{check sum}_{\text{hex}}$$

Example:

$$\text{check sum} = 255 - (1991 \text{ Modulo } 256) = 255 - 199 = 56 = 38_{\text{hex}}$$

The check sum is not transmitted as a hexadecimal character with 1 byte, but is translated into readable digits with 2 bytes. Through the comparison of the transmitted check sum with a check sum calculated at the read-out point, the user has the opportunity to check whether the transmission of the data is error-free.

Alarm codes:

<i>Temperature channel:</i>	<i>Humidity channel:</i>
A00 = no alarm, the temperature value is within the limits	A00 = no alarm, the humidity value is within the limits
A01 = temperature measurement range exceeded	A01 = humidity measurement range exceeded (=100% rh)
A02 = below temperature measurement range	A02 = below humidity measurement range (= 0% rh)
A03 = no sensor signal	A03 = no sensor signal
A04 = short circuit at PT1000 (resistance < 500 Ω)	A04 = humidity sensor defective

Software „VisualPMU“ (Freeware)

This simple and very clear visualisation software supports the data output of a sensor via a serial interface on the PC or Laptop without an additional power supply.

For this, it is necessary to install the accessory *Sub-D data line*. For USB connections, a *USB adapter* can be supplied.

The relative humidity, the dew point and the temperature (°C or F) can be displayed and can be depicted as a graph. Apart from that, the programme has a simple data logger function. Recorded data can be exported to other programmes.

This freeware version can be obtained from our Homepage www.galltec-mela.de as a free of charge download.

Accessories

Description	Product no.	Data sheet	Description
Sub-D data line RS232	as description	-	Sub-D data line 2.5m (for PM80VGS, PM80VKS, PM80VZS.H, PM80VZS.HD) <i>Caution: Plug on data line IP30 / -10...50°C !</i> When using the PM15VS, a commercially available 9 pin Sub-D jack can be mounted at the end of the cable <i>for wiring diagram see connection diagrams !</i>
USB adapter serial >USB	as description	-	USB adapter for Sub-D data line <i>To connect up the Sub-D-data line to a USB interface on the PC or Laptop</i>
ZA 24	as description	F5.1	Attachment plate for attaching ducts or wall bushings for sensor tubes 15 mm
ZA 161/1 with adapter sleeve 00.502	as description	F5.1	weather protection for rod sensors <i>recommended for outside use to protect from rainfall and sunlight</i> with adapter sleeve 00.502 also suitable for rod sensors 15 mm
AWG26C-UL	5303		shielded cable, interference immunity according to EN 80082-2 <i>recommended for connecting the sensors via EMC screw connection of the sensor</i> <i>Fitting the cable in the EMC screw connection must be done by a professional.</i>
ZE 31/1-12 ZE 31/1-33 ZE 31/1-75 ZE 31/1-84	as description	F5.2	Standard humidity to check the accuracy of the sensors 12 %rh and 25°C Standard humidity to check the accuracy of the sensors 33 %rh and 25°C Standard humidity to check the accuracy of the sensors 75 %rh and 25°C Standard humidity to check the accuracy of the sensors 84 %rh and 25°C

User information

Installation

The sensors are to be attached in a position representative for the climate measurement.

The position the sensor is mounted in (horizontal, vertical) does not matter. However, it should be mounted in such a way that no water can get into it.

Please note the maximum permissible ambient temperature for PMO and PMU when installing it. The transmitters always have to be installed in such a way that the connection plugs are not exposed to a higher temperature either (>85°C).

The duct sensor PM80VKS is mounted with an insulation length of 134 mm for use at 150°C (refer to dimension drawing).

Caution! The tightening torque when installing the pressure-resistant sensors (type PM80VZS.HD) may not exceed 25 Nm.

In a clean environment, the sensor is maintenance-free.

The capacitive MELA sensor element is also protected by the integrated PTFE filter. Dust does not cause any harm to the humidity sensor, however, if there is an increased build-up of dust this does affect dynamic performance.

If there is an excessive build-up of dust then you can carefully unscrew the filter and rinse it with distilled water. Loose dirt can also be removed from the PTFE filter above the measuring element by blowing it off or rinsing it carefully with distilled water.

Dew formation and splashes do not damage the sensor, although corrupted measurement readings are recorded until all the moisture on and directly around the sensor element has dried up.

Damaging Influences

Agents that are corrosive and contain solvents, depending upon the type and concentration of the agent, can result in faulty measurements and cause the measuring element to break down. Substances deposited on the sensor are damaging as they form a water-repellent film (this applies to all humidity sensors with hygroscopic measuring elements); e.g. resin aerosols, lacquer aerosols, smoke deposits etc.

In order to check functioning in the place of installation, we recommend that you use our *ZE31/1-type humidity standard... (accessories)* .

To ensure the given accuracy of the sensors, we recommend a calibration cycle of 6-12 months.

*) Additional Information

Please consult the **application instructions** for the sensing elements (product info sheet no. A 1 and B1.1), which you can get from www.galltec-mela.de, for further information which you need to bear in mind when using humidity sensors with capacitive sensing elements.

Dimensions

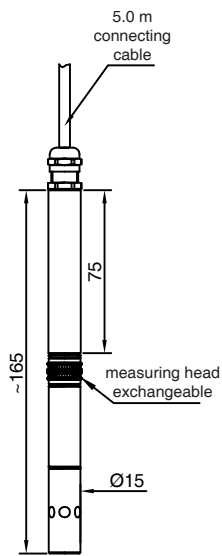

PM15VS
(rod sensor,
up to 85°C)

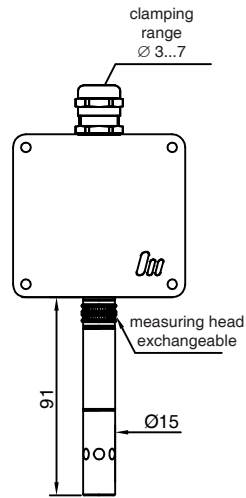

PM80VGS
(for wall-mounting,
up to 85°C)

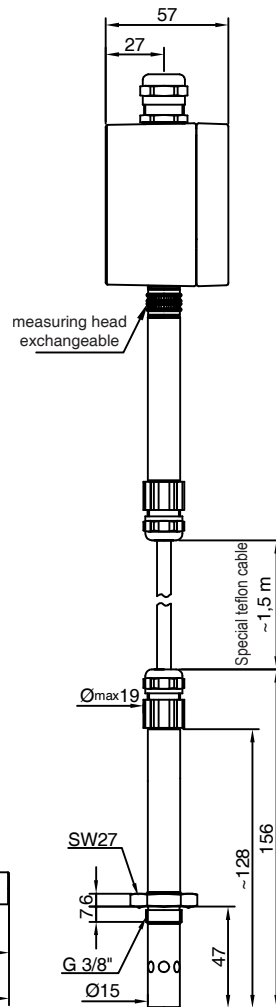

PM80VZS.HD
(up to 25 bar, up to 160°C)

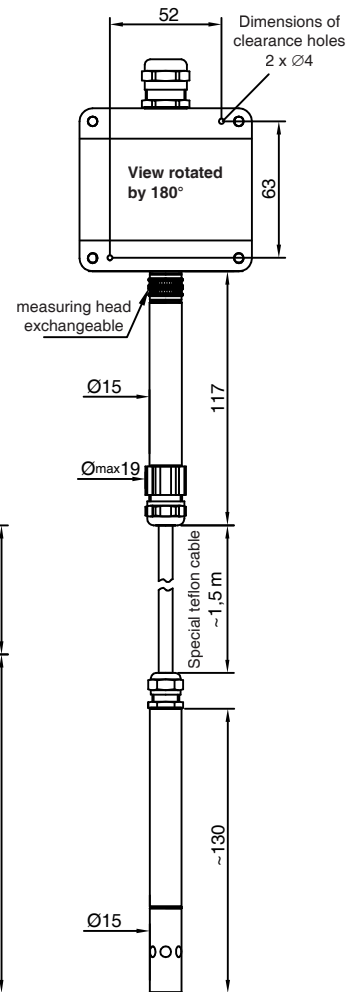

PM80VZS.H
(up to 200°C)

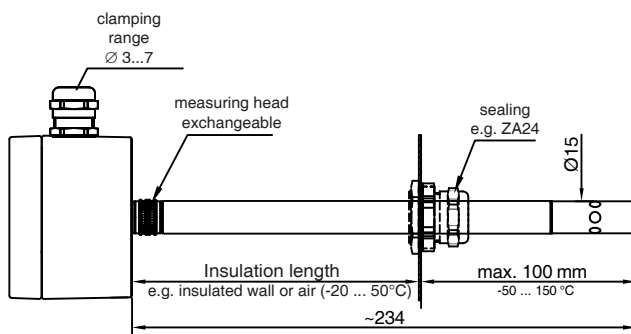

PM80VKS
(for duct mounting, up to 150°C)

Humidity-Temperature Sensor
Type PM15VS
Output: RS232

supply voltage
 5...30 V DC

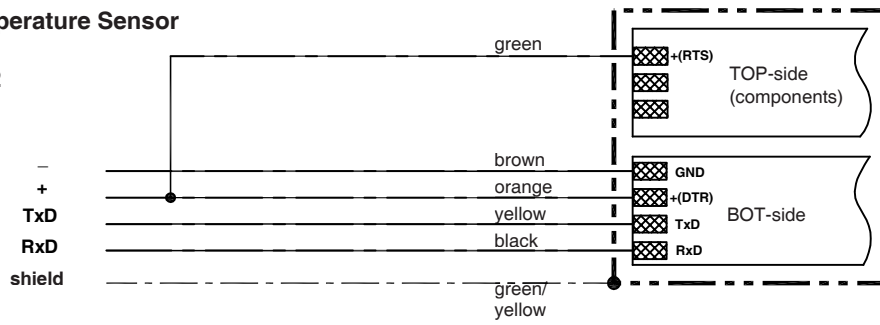

Wiring diagram for 9 pin Sub-D jack
Type PM15VS
Output: RS232

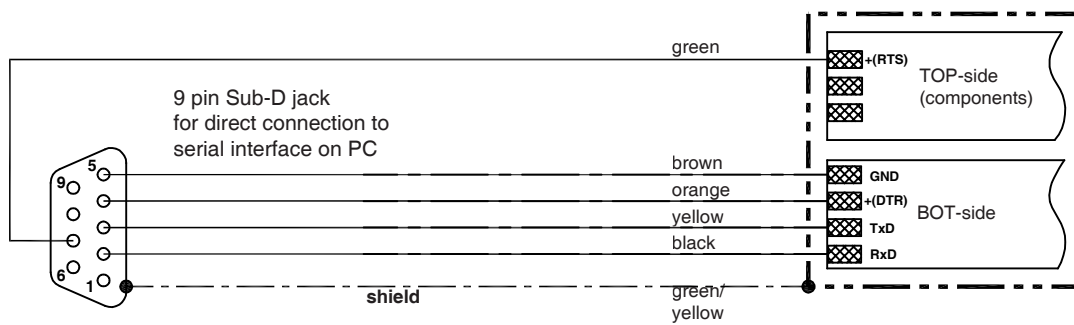

Humidity-Temperature Sensors
Types PM80VGS, PM80VKS, PM80VZS.H and PM80VZS.HD
Output: RS232

supply voltage
 5...30 V DC

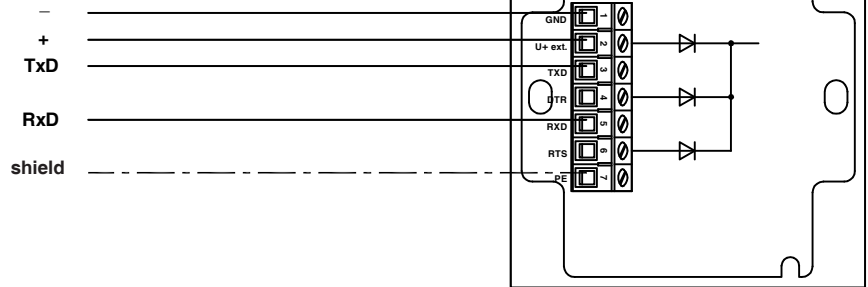

Wiring diagram for Sub-D data line 2.5 m (accessories)
Types PM80VGS, PM80VKS, PM80VZS.H and PM80VZS.HD
Output: RS232

