

**Description of the Hygrostat**

The humidity measuring element, produced by Galltec® under the name „Polyga®“, consists of several synthetic fabric bands each with 90 individual fibres with a diameter of 0.003mm. A special process gives the fibre hygroscopic properties. The measuring element absorbs and desorbs humidity. The swelling effect, which is predominantly in a lengthways direction, is carried via a suitable lever system to a microswitch with an extremely small switching path. The measuring element reacts quickly and precisely to the change in air humidity. By adjusting the set value control knob, the lever system is engaged so that when the set air humidity is reached the microswitch is activated.

In the case of the hygrostat type HG80-2, a second microswitch is positioned parallel to the first microswitch. After the housing cover has been removed, the second set value can be finely adjusted at the microswitch lever using a screwdriver. The switch point of the second microswitch is connected to the switch point of the first microswitch. The switch distance (neutral zone) can be set from 0% rel. humidity to +15% rel. humidity.

The fan shaped measuring element is protected by a perforated sensor tube and is exposed to the housing. The hygrosats are designed for pressureless systems. The mounting position should be chosen such that condensed water cannot get into the interior of the housing. The preferred mounting position is with the „sensor vertically downwards“ or „sensor horizontal“ (see diagram on the reverse). In the mounting positions described above, a blanking plate in the sensor tube with a 0.8mm diameter hole will prevent water getting in.

**Hygrostat**

with "Polyga®"

humidity measuring element

with one or two changeover contacts

with inner rotary knob or set point protection

measuring range 30...100%rh.

**HG 80****HG80-2****HG80i****HG80vs****Application**

The hygrostat type HG80 is used as an on-off controller to control the relative air humidity in air ducts of air conditioning units and climatic cabinets, and to control air humidifiers and dehumidifiers. Other areas of use are storage of food-stuffs and luxury foods, cooling rooms for fruit and vegetables, greenhouses for gardening use, the textile industry, the paper and printing industry, film industry and hospitals.

The **hygrostat HG80** can be used almost anywhere that air humidity has to be regulated or monitored.

**Technical Data**

measuring range (scale range) ..... 30...100%rh  
measuring accuracy

for measuring range &gt; 50%rh ..... ±3.5%rh

for measuring range &lt; 50%rh ..... ±4.0%rh

setting range (range of operation) ..... 35...100%rh

measuring medium ..... air, pressureless, non-aggressive

switching difference (microswitch) ..... ca 3...6%rh

switching distance

between the microswitches for the HG80-2 .... 0...+15%rh

max. voltage ..... 250 V AC

!!!Caution: 250V only on condition that there is no build-up of condensate in the measuring head - otherwise voltage arcing may result.

breaking capacity of the changeover contact

ohmic load (cos φ=1) ..... 15 A AC 230V

inductive load (cos φ=0,7) ..... 2 A AC 230V

direct voltage ..... 0,25 A DC 230V

at low voltage ..... 100 mA, 125 V AC

contact material ..... silver

allowable ambient temperature ..... -30...+60°C

allowable working temperature ..... 0...60°C

medium temp. coefficient ..... -0,2%/K relative to 20°C and 50%rh

adjustment ..... at average air pressure 430 m NN

allowable air speed ..... 8m/sec

with gauze protection (ord no. 20.014) ..... 15m/sec

time constant T<sub>63</sub> at v=2m/sec ..... 120 sec

sensor length, material ..... 220mm, high-grade steel

fixing ..... slots in the housing base for duct mounting

(ord. no. 20.009) ..... console for wall mounting

mounting position ..... sensor vertically downwards

or horizontally

connecting terminals .... for conductor cross sections 1.5mm<sup>2</sup>

cable connection ..... via twist nipple M20x1,5

electromagnetic compatibility EMC

resistance to interference ..... ref. EN 50 082-2

interference emission ..... ref. EN 50 081-2

housing ..... ABS light grey

type of protection (outer rotary knob) ..... IP 54

type of protection (inner rotary knob HG80i, HG802i) ..... IP 64

weight ..... 0.7 kg

"subject to technical modifications"

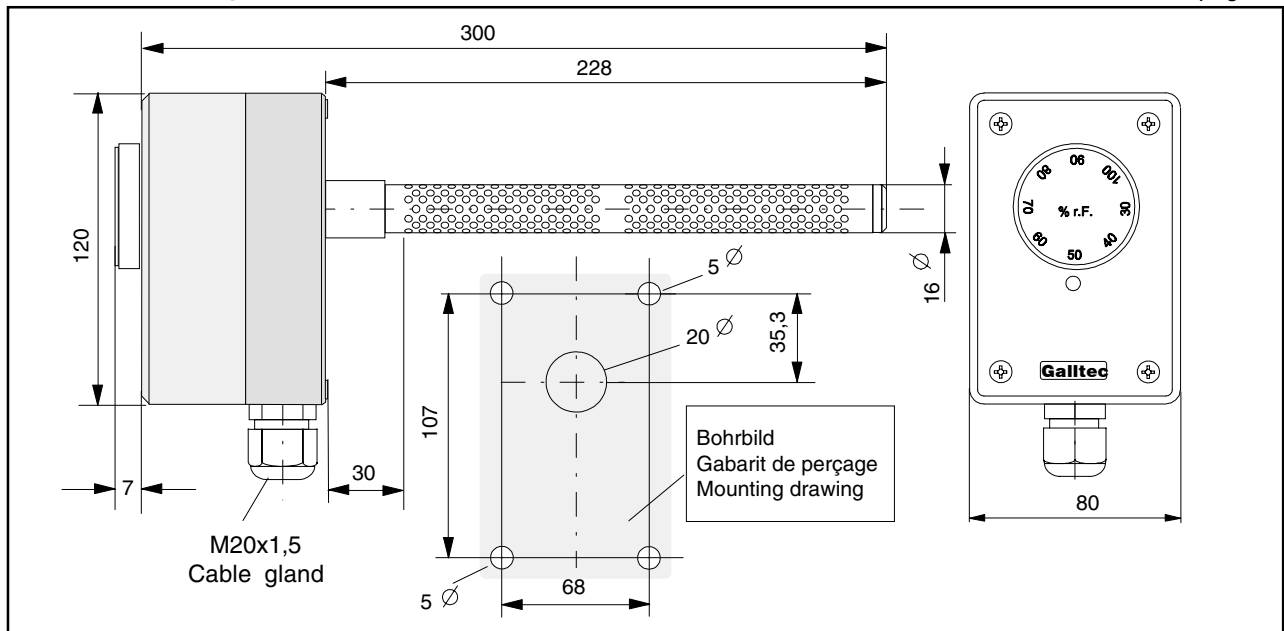

Connection diagram

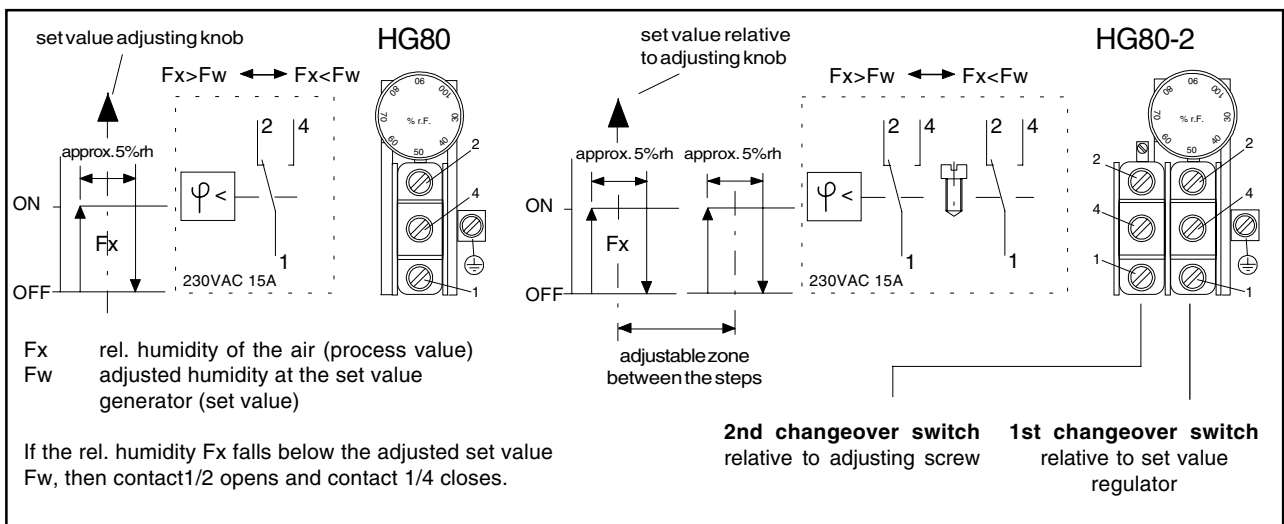

Adjusting the 2nd set value

The hygrostats HG80-2(i) are set by the factory such that the 2nd set value is 6% rel. humidity higher than the 1st set value.

The neutral zone (distance between the 1st and 2nd set value) can be adjusted after removing the housing cover using a screwdriver. If turned to the left, the 2nd set value goes up (from 0%rh to +15%rh relative to the 1st set value). The neutral zone can be read using the rotary knob.

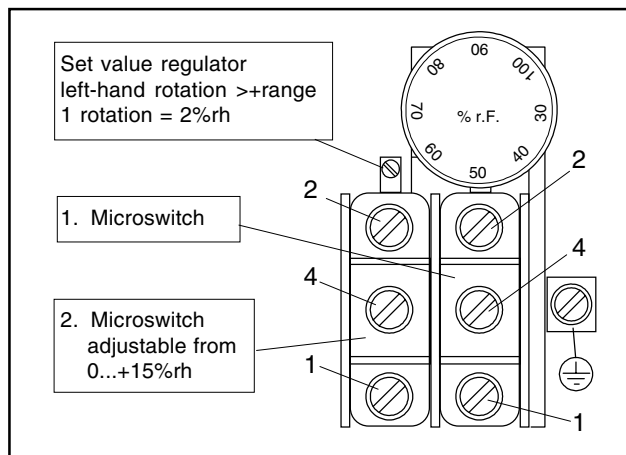

Accessories

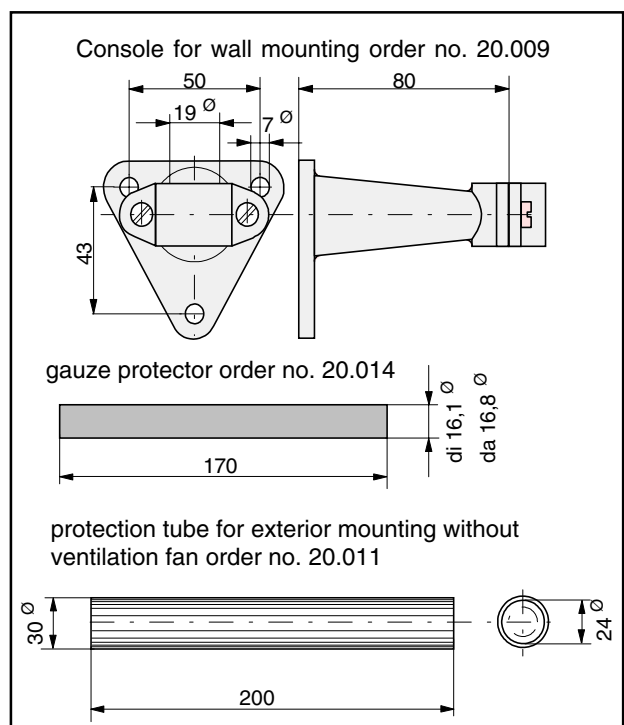

## Operating instructions for channel hygrosat HG80 and HG80-2

### Mounting

- > The hygrosats must not come into direct contact with water (e.g. splashed water when cleaning the climatic chamber etc.)
- > The mounting location should be chosen so that a representative measurement of the air humidity can be guaranteed, i.e. the humidity readings at the mounting location should correspond to those in the room as far as possible.
- > The hygrosat should be exposed to the flow of air.

### Operating information:

Note that, with restrictions in the upper range of operation, the possible tolerances (measurement accuracy, switching difference and temperature coefficient) should be observed when adjusting the switch point.

### Preferred mounting positions

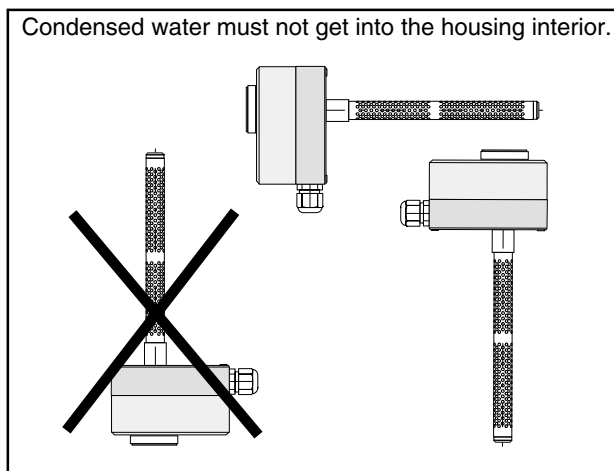

### Exterior mounting

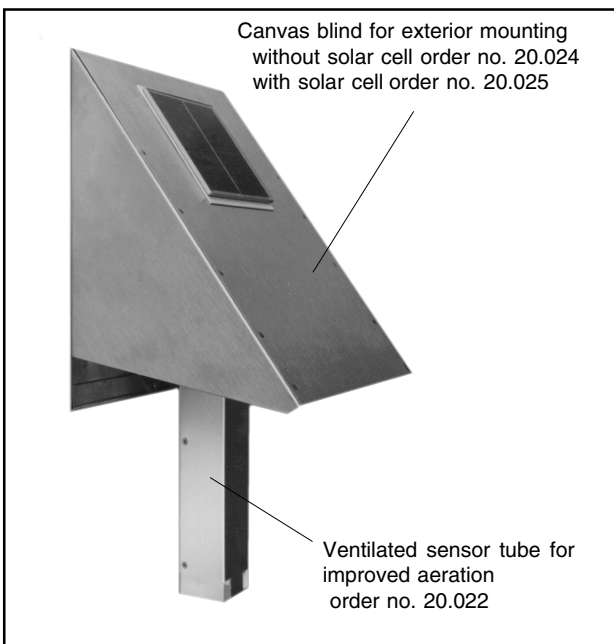

### NOTE:

Contact with the inner parts nullifies the guarantee.

### Calibration

Equipment with Galltec® hygrosats is correctly set by the factory at a room temperature of 23°C and 50% rel. humidity, relative to the average air pressure of 430m NN.

If, however, subsequent adjustment should be necessary, the following procedure should be observed.

- > Ensure that the ambient humidity and the ambient temperature are constant.
- > If possible, use a psychrometer for checking (no checking equipment with capacitive sensors).
- > Leave the equipment to be checked for at least *1 hour in a constant checking climate*.
- > The adjuster screw is at the end of the sensor - fixed with screw securing lacquer. After removing the lacquer, the adjuster screw can be moved. A right-hand rotation means that the measured value goes down, and with a left-hand rotation the measured value goes up. After calibration, the adjuster screw should again be secured.

### Note:

Moving the adjuster screw nullifies the guarantee.

**Important.** The water absorption capacity of the air is influenced, amongst other things, by the temperature. This is a physical law (which can be seen from the hx diagram of Mollier). The higher the air temperature, the greater the volume of water vapour that can be absorbed up to saturation point (100%rh). If a hygrosat is now calibrated at fluctuating air temperature, there is an irregular, non-homogeneous measured medium and there are automatically calibration errors. The table below shows the influence of the air temperature on air humidity. If, for example, calibration occurs at an air temperature of 20 °C and 50%rh, and at a temperature fluctuation of just  $\pm 1$  °K, then there will be a humidity fluctuation in the measured medium (air) of  $\pm 3.2\%$ rh.

|       | 10°C           | 20°C           | 30°C           | 50°C           |
|-------|----------------|----------------|----------------|----------------|
| 10%rh | $\pm 0,7\%$ rh | $\pm 0,6\%$ rh | $\pm 0,6\%$ rh | $\pm 0,5\%$ rh |
| 50%rh | $\pm 3,5\%$ rh | $\pm 3,2\%$ rh | $\pm 3,0\%$ rh | $\pm 2,6\%$ rh |
| 90%rh | $\pm 6,3\%$ rh | $\pm 5,7\%$ rh | $\pm 5,4\%$ rh | $\pm 4,6\%$ rh |

### Maintenance

The measuring element is maintenance-free in pure ambient air. Aggressive media containing solvent can cause measuring errors and failure, depending on the type and concentration. As with almost all humidity measuring elements, deposits which eventually form a water-repellent film over the sensor are harmful. Such substances are resin aerosols, lacquer aerosols, smoke deposits etc. The water-resistant property of the Galltec® measuring elements allows cleaning to be carried out in water. Solvents cannot be used for this purpose. A light-duty detergent is recommended, but any residue should always be washed out thoroughly.

A special process ensures that Galltec® sensors have good long-term stability. Regeneration is not necessary, but is also not harmful.

### Maintenance regulation

for humidity measuring equipment with "Polyga®"humidity measuring element.

### Impact of dirt

The measuring element is maintenance-free in pure ambient air. Aggressive media containing solvent can cause measuring errors and failure, depending on the type and concentration. As with almost all hygroscopic humidity measuring elements - and these include particularly the capacitive measuring elements, resistive measuring elements and fibre measuring elements (Polyga) - are sensitive if a water-repellent film forms on the surface of the elements. Such sensors and hygrometers cannot be used for example during wood drying as, depending on the type of wood to be dried, resin aerosols in the surrounding air are deposited on the measuring element. The same applies to lacquer drying equipment where there are paint aerosols in the surrounding air. Here, the psychrometer sensor (Galltec® type FEP3) has advantages in spite of the heavy maintenance involved.

The water-repellent property of the Galltec® humidity measuring element allows cleaning to be carried out in water. An important benefit<sup>33</sup>.

### Cleaning instruction

for humidity sensors, hygrometers in channel design as well as all shaft equipment, FG80..., TFG80..., HG80, HG80-2.

The humidity measuring equipment is designed with a perforated sensor tube. The humidity and temperature measuring elements are in the interior of the sensor tube. The humidity measuring element is arranged axially and the temperature measuring element is seated sideways at the top or bottom between the perforation holes.

Measuring equipment with Pt100 glass measuring resistors can be immersed in water. Other temperature sensors, in particular semi-conductor sensors or customer-specific temperature sensors should not come into contact with water. Enquire if in doubt.

The measuring elements are designed for use in pressureless air (gases). The measurement accuracy depends on the degree of pollution of the element. The humidity measuring element, in particular, loses its hygroscopic properties if the surface is covered with grease, soot, smoke deposits, paint, resinous substances etc. By cleaning the elements, their function can be reproduced, but only if no damage is caused by acids, alkaline solutions or other aggressive substances.

### Cleaning process

1. Dip the sensor tube into a receptacle containing clean water (20°C) and, with a gentle rotating motion, disperse the dirt deposits. If the dirt contains grease deposits, it is recommended that a mild detergent be added to the water.

***Do not brush or treat with any other cleaning utensils. Only the sensor tube should be immersed - not the housing.***

The sensor tube is open to the housing interior (0.8mm hole)

2. As mild detergents are known to contain chemical substances, rinse carefully after cleaning. Cleaning residue will impair the measured result.

3. Air drying. Where a measuring element is moistened with water, the device indicates 100% relative humidity. If necessary, it is possible to carry out sensitive recalibration at the adjusting spindle at the end of the sensor. This should only be done where there are large deviations. Slight movement of the adjusting spindle of a wet element causes the measured value in the dry area to be badly out. Here, there is an intensifying effect of the linearisation (factor 6).

Indications of 98..100% relative humidity at the wet element are adequate.

The accuracy in the dry area must be determined under normal climatic conditions.

***The measuring element must not be dried using warm or hot air (hair dryer).***

Cleaning should be carried out for no longer than some seconds.

### Cleaning instruction

for humidity sensors in room design, FG120..., TFG120..., HG120(-2), HGMini and equipment with an interior measuring element.

The units described above also apply to this equipment.

1. Unscrew the cover. Clean the cord shaped measuring element using a soft brush and clean water. Do not use a detergent as it cannot be dispersed.

***It is important that no water is allowed to get onto the other components, particularly microswitches, terminals, printed circuit boards, potentiometers.***

2. Air drying.

***Do not use warm or hot air (hair dryer).***

Affects recalibration. See also the section for duct equipment headed Cleaning Instruction.

### Installation Advises

On installation ensure that there is sufficient overcurrent protection (e. g. fuse). Also a separation device (e. g. plug or switch) has to be installed.

December 1978 - revised December 2001