



Technical data

Humidity

Measuring range 0...100%rh
 Accuracy (MR 5...95%rh at 10...40°C) ±2%rh
 at <10°C, >40°C <0.1%/K additional
 Response time (at calm air) < 20 s

Temperature

Measuring element (DIN EN 60751) Pt 100 class B
 Measuring range -30...+70°C
 Accuracy
 Output: 0...1V (-27...70°C) ±0.2 K
 0...10V (-29...70°C) ±0.2 K
 4...20mA -0.2...+0.6 K
 at <10°C, >40°C ±0.007 K/K additional

Other data

Ambient temperature -40...+80°C
 Degree of protection sensor/electronic IP 40/IP 65
 Operating voltage:
 I-Output 12...30V DC
 U-Output (0...10V) 15...30V DC
 U-Output (0...1V) 6...30V DC
 Load resistance (0...10V, 0...1V) ≥10kΩ/≥2 kΩ
 Load (current-output) acc. diagram
 Power consumption
 0...10V, 2 x 0...1V <5 mA
 0...1V <1 mA
 Minimum air speed (across the sensor)
 Output: 2 x 4...20mA ≥1.5 m/s
 4...20 mA, 2 x 0...10 V ≥1 m/s
 0...10V, 2 x 0...1V ≥0.5 m/s
 Self-heating Pt 100 (1 m/s, 2mA, 20°C) 0.1 K
 Electromagnetic compatibility
 Emitted interference EN 55011 cl. B
 Noise immunity EN 50082-2
 „subject to technical modifications“

Product info sheet no. C 4.2
Humidity / temperature sensors

Compact sensors in a high-grade steel housing

Description

MELA-humidity/temperature sensors in the VC and VR series are compact humidity or humidity/temperature sensors in a high-grade steel housing with a fixed connecting cable or with a sturdy connecting head. All sensors in the series are equipped with a sintered high-grade steel filter type ZE13. They have been specially developed for use in extreme conditions and are used to measure relative humidity or relative humidity and temperature in air and in other non-aggressive gases. Their design also makes them ideally suited for performing equilibrium humidity measurements in bulk materials and in brickwork.

Use of capacitive humidity sensor elements is a guarantee of:

- high long-term stability
- almost linear characteristic curve
- good dynamic performance
- resistance to dew formation
- small hysteresis.

Type versions

Measured variable	Analogue output	VC series 1.5m cable	VR series connecting head
F rel. humidity	4...20 mA	FVC 3/5	FVR 3/5
	0...10 V	FVC 2/5	FVR 2/5
	0...1 V	FVC 1/5	FVR 1/5
C r.h. + temp.	4...20 mA, Pt100	CVC 3/5	CVR 3/5
	0...10 V, Pt100	CVC 2/5	CVR 2/5
	0...1 V, Pt100	CVC 1/5	CVR 1/5
K r.h. + temp.	2 x 4...20 mA	KVC 3/5	KVR 3/5
	2 x 0...10 V	KVC 2/5	KVR 2/5
	2 x 0...1 V	KVC 1/5	KVR 1/5
approx. weight		150 g	130 g

Special versions available on request.

Tolerance validity range for humidity

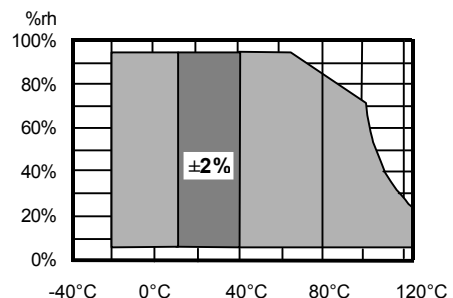

These details reflect our latest findings and are intended to supply information about our products and possible areas of application for them. Therefore, they are not meant to be guarantees that the products contain certain properties or that they are suitable to be used for specific purposes. In the past, the devices have been used for a wide range of purposes under very differing conditions and loads. We are unable to assess every single case. It is up to the buyer or user to assess the suitability of the devices. Due account must be taken of any existing commercial patent rights. We guarantee that the products are of excellent quality, within the scope of our General Terms and Conditions of Sale. Published: September 2005, valid until 31.12.2008 C42_E. Subject to modifications, current version available at www.galltec.de. This issue supersedes all previous technical leaflets.

User instructions

Install the MELA-sensors at a place in the room, plant or equipment where characteristic levels of humidity occur. Avoid installing them close to heaters or walls or against outside walls.

The specified minimum air speed and - with current output - the load according to the operating voltage (diagram) should be complied with in the case of the VC and VR series. Deviations may lead to additional measuring faults resulting of the self-heating of the sensor (clocked operation will help to avoid this).

The sensor can be installed in any position. However, do avoid positions where water can enter. Dew formation and splashes do not damage the sensor, but can result in faulty measurements until all the moisture on and directly around the sensor element has dried up.

In order to maintain interference immunity in accordance with EN 80082-2 while in use, we recommend to use a shielded cable (**type recommended: 8x AWG 26 C UL, order no. 5339**) for connection of the VR sensors and have it fitted correctly into the sensor's EMC cable gland by a qualified electrician.

Dust does not cause any harm to the humidity sensor, however, it affects the dynamic performance.

If the sensor element is very dirty, the dirt can be blown off or the element can be rinsed carefully in distilled water. Never touch the highly sensitive sensor element.

The sintered protective cage should be in an absolutely dry condition when it is screwed on again in order to avoid measurement errors.

As a mounting support we recommend the **mounting plate type ZA 24** (stainless steel base plate with brass screw connections) or **ZA25** (stainless steel base plate with

stainless steel screw connections) (see product info sheet no. F 5.1). For easy function control at the place of installation, we recommend to use the **ZE 31/1-type humidity standard** with a **ZE 33-type auxiliary adapter** (product info sheet no. F 5.2).

The humidity sensor can also be used for measuring the humidity of the material via the measurement of the equilibrium humidity. Therefore insert the sensor head far enough into the material to be measured (e.g. bulk material or brickwork) and seal it in order to eliminate any connection with the ambient humidity in the room. The relative humidity is measured, which is a measure of the moisture of the material, as equilibrium humidity via the sorption isotherms of the material

Please consult the **application instructions for the sensing elements** (product info sheet no. A 1) or check with the manufacturer for further information which you need to bear in mind when using humidity sensors with capacitive sensing elements.

Load of current output:

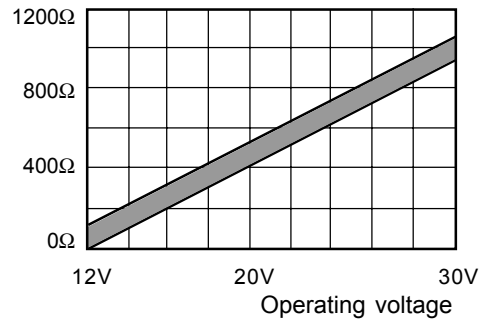

Dimensions

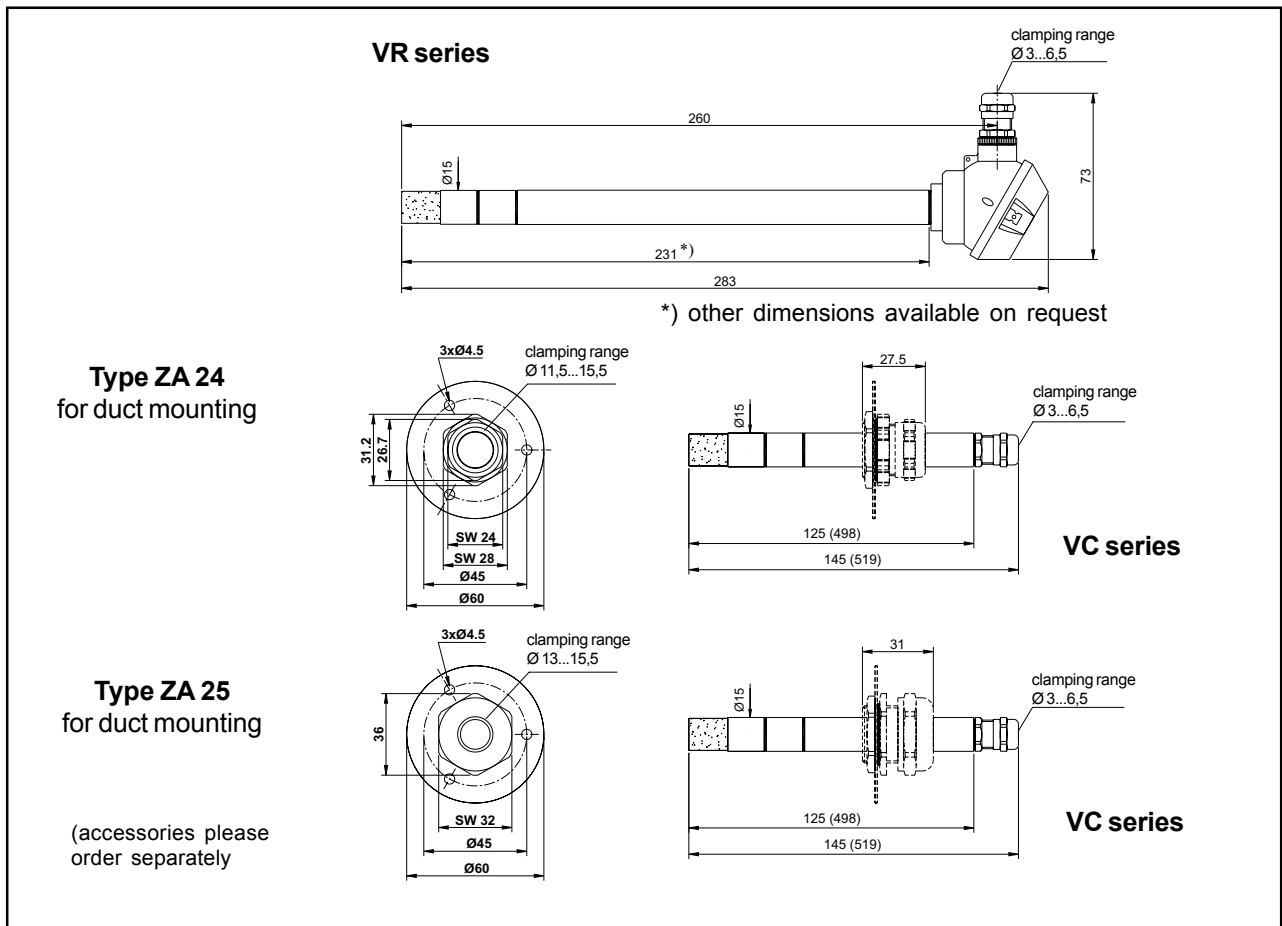

Connection diagram

Humidity/-temperature sensors

Compact sensors in a high-grade steel housing
series VC

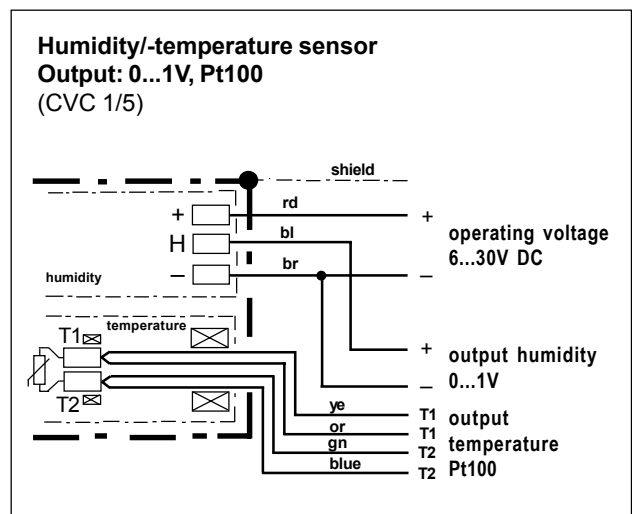
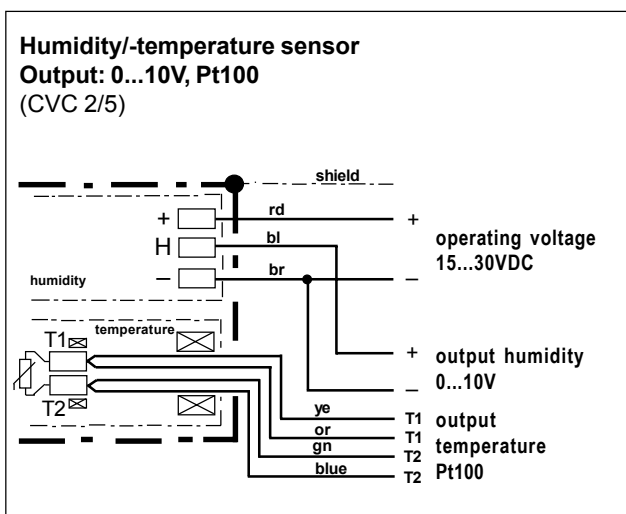
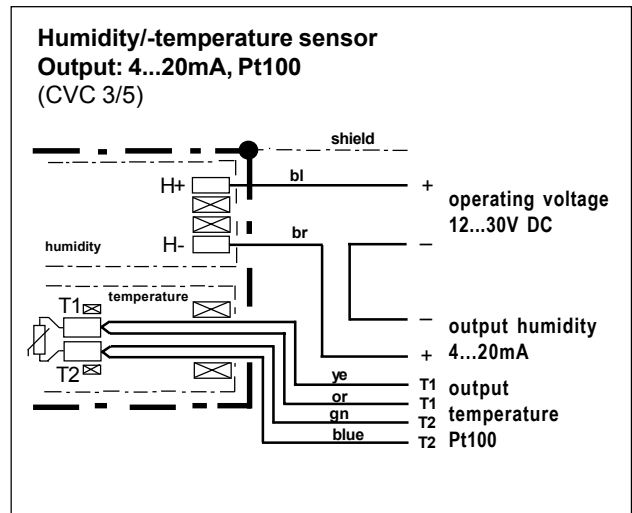
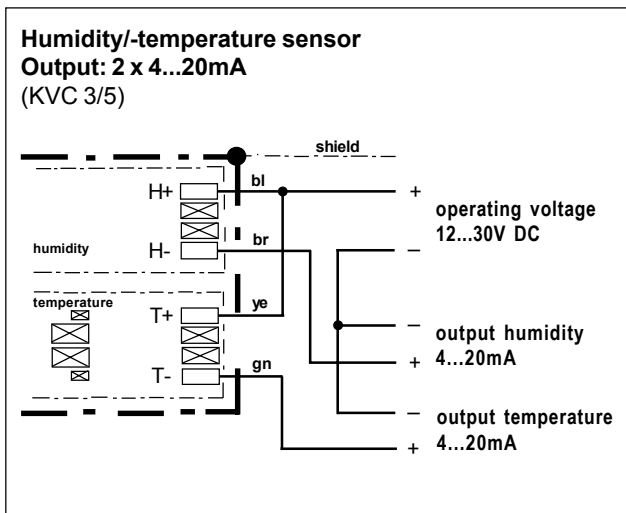
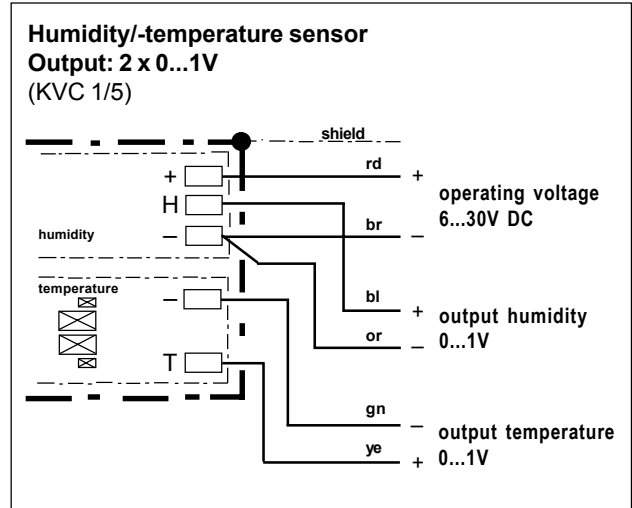
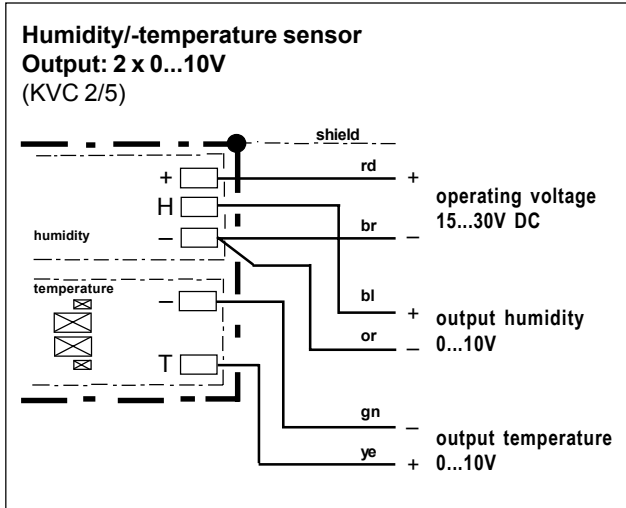

Connection diagram

Humidity/-temperature sensors

Compact sensors in a high-grade steel housing
series VC

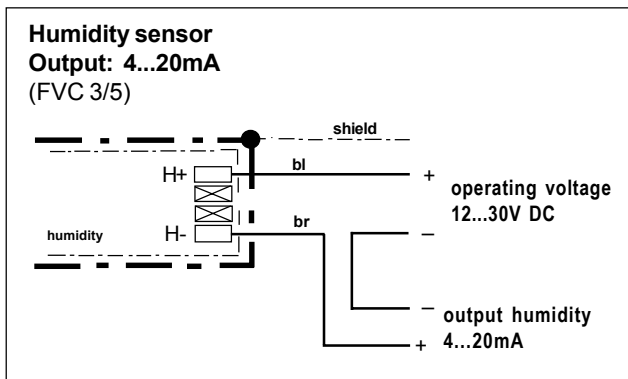
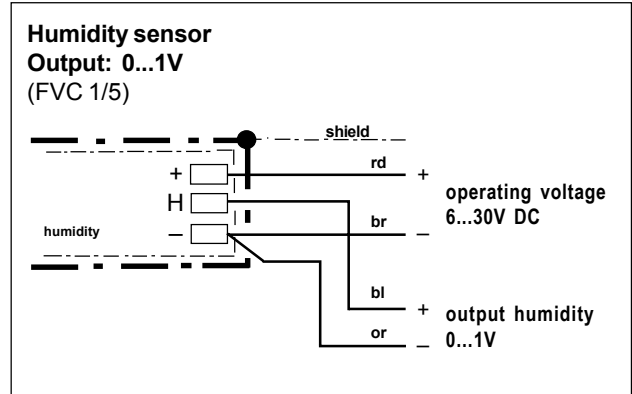
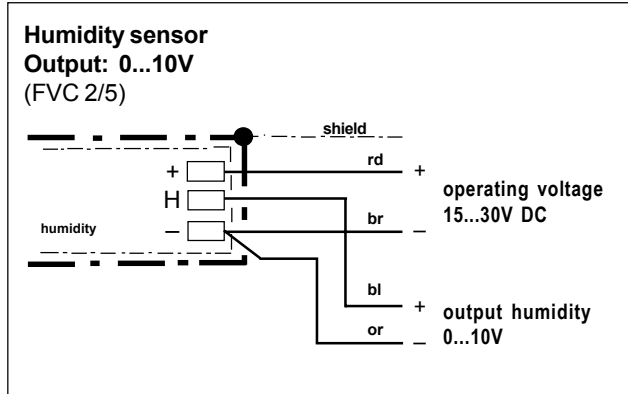

Connection diagram

Humidity/-temperature sensors

Compact sensors in a high-grade steel housing series VK

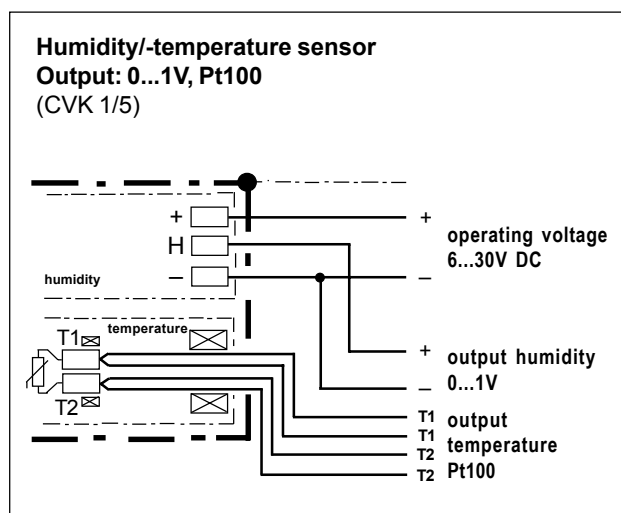
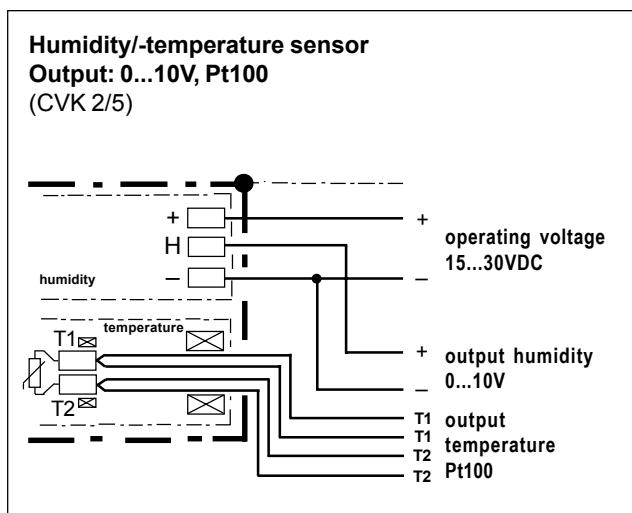
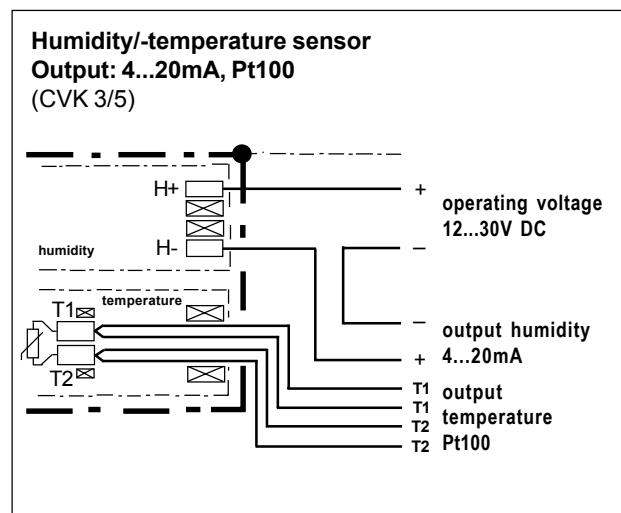
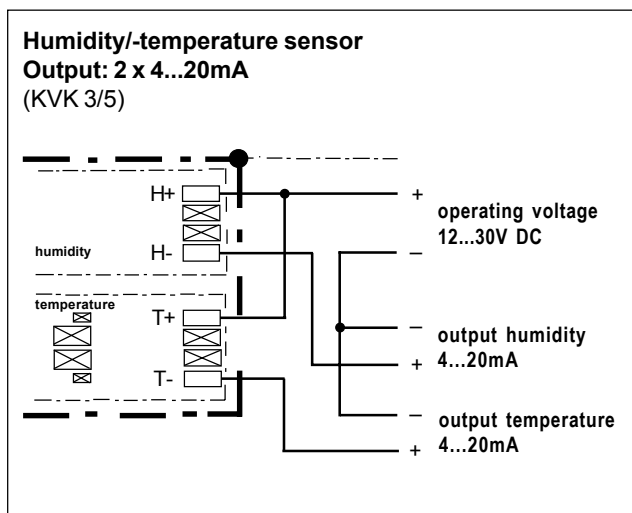
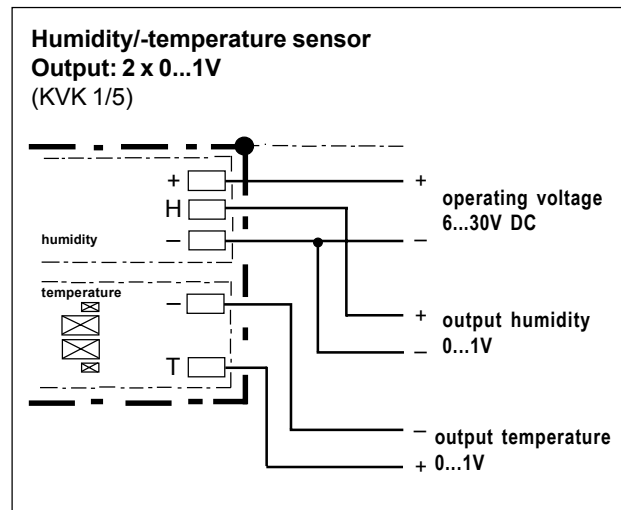
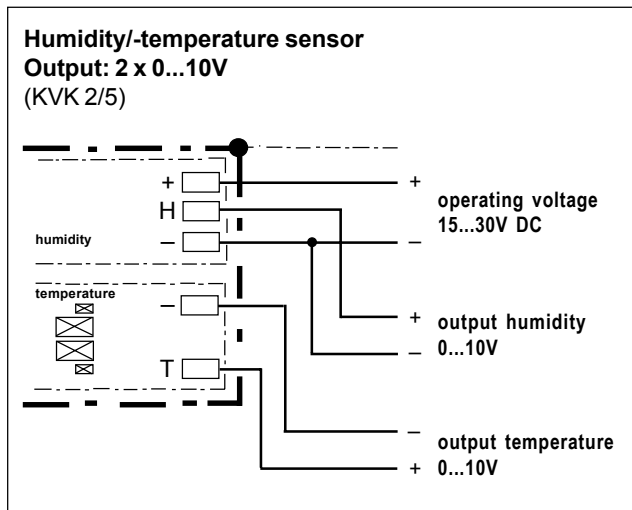

Connection diagram

Humidity/-temperature sensors

Compact sensors in a high-grade steel housing
series VK

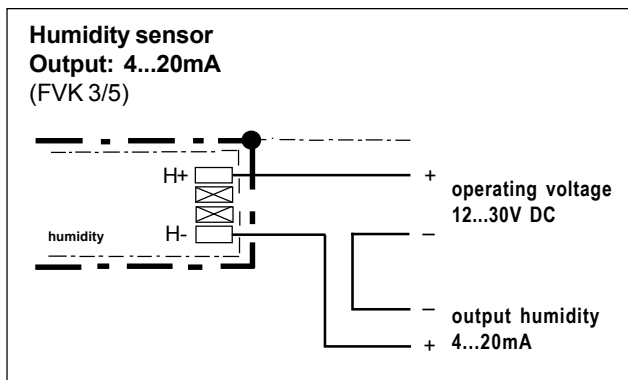
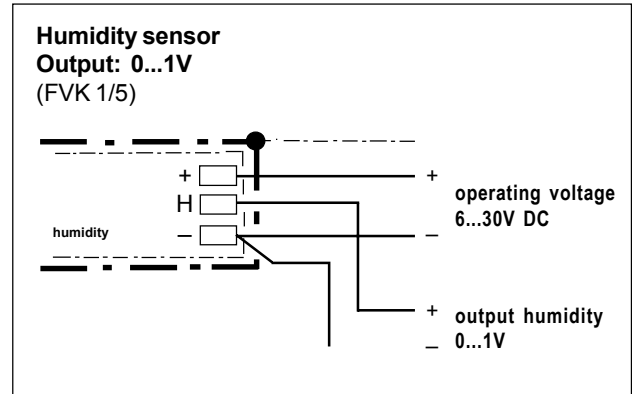
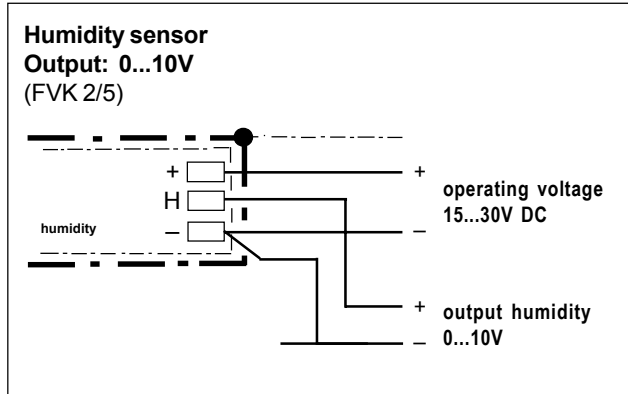

Connection diagram

Humidity/-temperature sensors

Compact sensors in a high-grade steel housing series VR

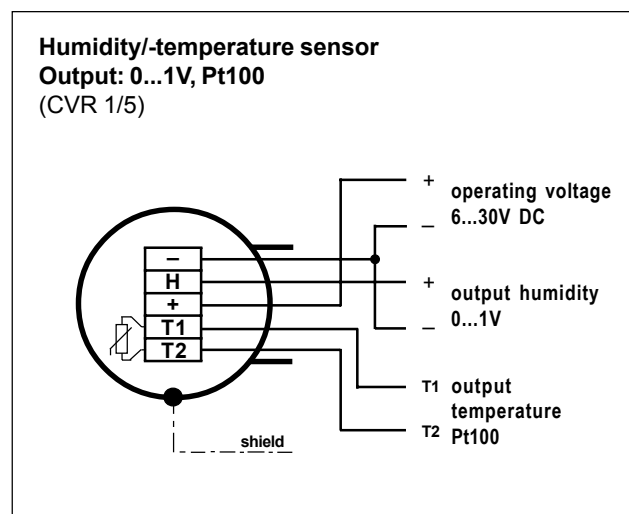
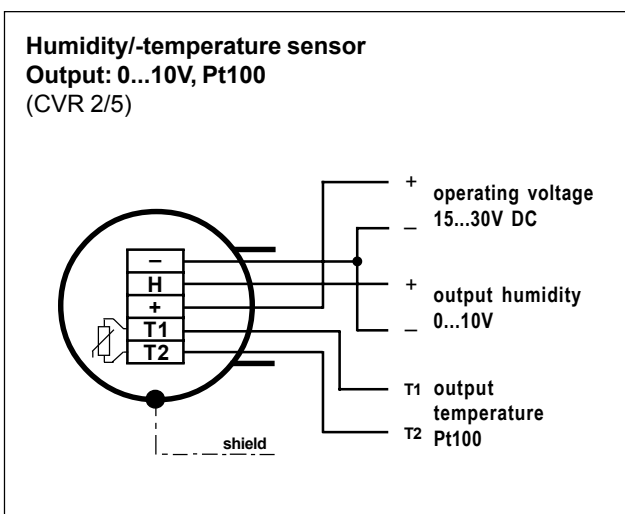
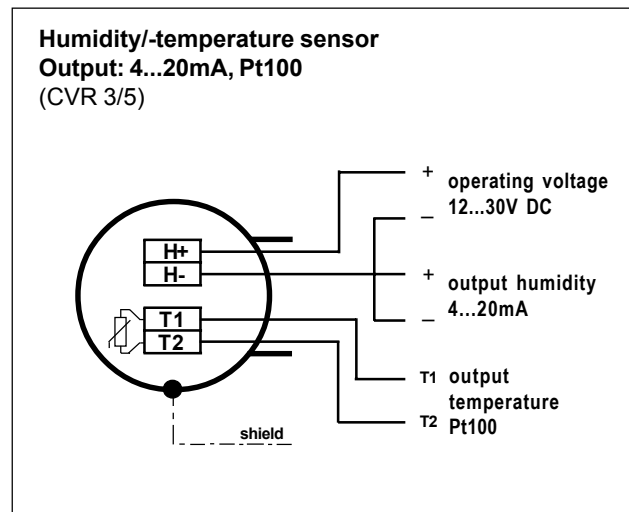
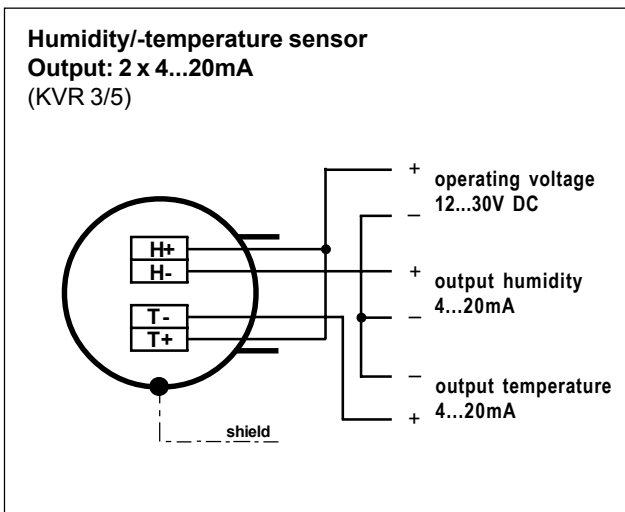
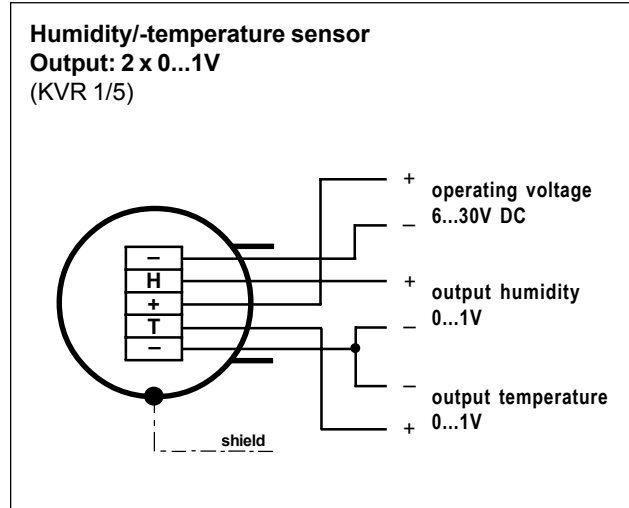
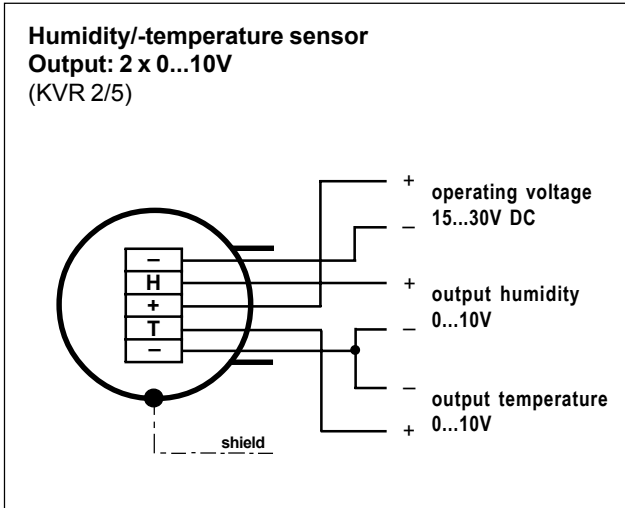

Connection diagram

Humidity/-temperature sensors

Compact sensors in a high-grade steel housing
series VR

