

FLTA BASE STATION FOR WIRELESS SENSORS / IO-MODULES

FLTA is a base station for wireless transmitters, detectors and IO-modules using 868.30 MHz frequencies. Incoming information will be forwarded to the control or BMS by using Modbus communication or eight analogue outputs of the base station. Respectively the control information coming via Modbus will be forwarded to the IO-modules. The FLTA module has 8 x 0...10Vdc outputs that can be configured for example for temperature, humidity, set point or 5-position switch and also for those analogue / digital signals from LAFL detectors and RYFL IO-modules.

FLAN antenna for FLTA is always needed to ensure reliable transmission between base station and transmitters / IO-modules. The transmission area can be extended by using FLREP or FLREP-U repeaters (up to 8 pcs) between transmitters / detectors / IO-modules and the FLTA base station.

Each FLTA control module can have up to 99 transmitters or IO-modules in its operating area. Up to 63 FLTA base stations can operate in the same wireless area. In theory totally 6,237 transmitters and IO-modules can be connected in a single system.

During commissioning each base station must have its own address MID (Master ID) entered by using buttons and display of the base station (see installation and service guide / instructions).

Changed measurement readings are transmitted immediately. FLTA base station receipts each message and generates alarm if at least one message is missing more than one hour. When Modbus network is activated this information (= alarms) is available only via Modbus. When Modbus network is not activated alarm information is available as a 5Vdc voltage output from the terminal 4 (B-) against Go level. Also the display of the base station shows this alarm information.

After the break of supply the outputs of FLTA base station are returning to the status which was prevailing before the break.

Wiring:

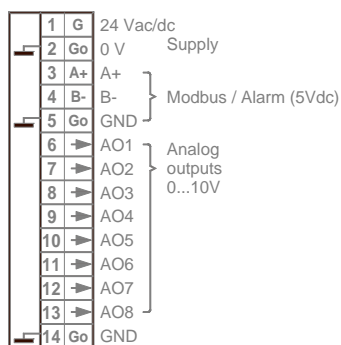

Technical data:

Supply	24Vac/dc (22...28Vac/dc), 2 VA
Frequency	868.30 MHz, Class 1
Range	500m line in sight 20 ... 100m in buildings +8 dBm
Transmission power	+8 dBm
Reception sensitivity	-109 dBm
Modulation	FSK
Outputs, 8 pcs 0-10V with TEFL-P-RH-S5	temperature 0...50°C humidity 0...100% RH set point 18...24C 5-pos. switch 1...5V (e.g... position 3 = 3V) humidity 0...100% RH temperature -50...+150°C light level 0...1000 lx temperature -50...+150°C voltage 0...10V occupancy 0 / 10V light level 0...2000 lx voltage 0...10V digital input 0 / 10V Modbus RTU (RS485)
with KLUFL	
with TEUFL	
with LAFL-LX	
with RYFL	
Communication	
Ambient:	
temperature	-25°C... +65°C
humidity	0...100 % RH (non-condensing)
Housing, protection class	ABS-plastics, IP20
Dimensions w x h x d	53 x 90 x 58 mm

Ordering guide:

Model	Product nr	Description
FLTA	1191030	base station
FLAN	1191040	antenna for base station
FLANJJ-4.5	1191041	antenna extension cable 4,5m

Products fulfill the requirements of directives 2004/108/EC, 2006/95/EC, 1999/5/EC and 2000/299/EC and are in accordance with the standards EN61000-6-3 (Emission), EN61000-6-2 (Immunity), EN60730, EN300220-2 and EN301489-3.

Produal Oy

Keltakalliontie 18
48770 Kotka
FINLAND
www.produal.com

Tel: +358-5-230 9200
Fax: +358-5-230 9210
info@produal.fi